

AUTOMATIC VEHICLE RESTRAINT

- ▶ Industry proven truck positioned restraint mechanism
- ▶ Push Button Activation
- ▶ Advanced three light communication system
- ▶ LED internal and external lights
- ▶ Low profile 9" carriage - service range 9"-30" off grade
- ▶ Restraining force in excess of 32,000 lb average
- ▶ Zinc plated track and housing provides high corrosion resistance
- ▶ IP67 rated motor, submersion proof up to 1 meter
- ▶ On-demand motor operation to preserve energy
- ▶ Exclusive designed gear motor keeps hook continuously engaged
- ▶ Made in the USA
- ▶ iDock[®] Controls with interactive Message Display

GENERAL DESCRIPTION: All McGuire[®] TPR[®] truck positioned vehicle restraints are designed to secure a cargo trailer's rear impact guard (RIG) to reduce the likelihood of premature trailer separation during the loading/unloading process. The TPR vehicle restraint features an electric mechanical restraint mechanism, inside iDock control panel, exterior communication lights and instructional signs.

OPERATION: As the truck backs into position, the Rear Impact Guard "RIG" contacts the "TPR" spring loaded structural steel housing which rides down its track, allowing the RIG to position itself on top of the housing. The exterior communication light is green and the interior light is red. Once trailer is positioned against the dock bumpers, the operator presses the "Engage" button allowing the hook to secure the trailer to the loading dock. Once restrained, the interior light is green allowing the dock attendant to safely enter the trailer while the exterior light is red warning the driver not to pull away from the dock. The "TPR" restraint maintains contact with the RIG and adjusts automatically with the trailer float motion to assure proper engagement at all times during the loading/unloading operation. After the loading is complete, the operator presses the "Release" button. When the trailer is released and the restraint is safely stored the interior light changes to red while the exterior light changes to green.

If the "TPR" is unable to secure the trailer's RIG, the restraint will communicate the fault condition, on the message display and by flashing an amber "caution" light. If "By-Pass" of the system is necessary, it is recommended that you secure the trailer by other means before proceeding with the loading/unloading process. In "By-Pass" mode the exterior light is red the interior amber caution light accompanies the green light indicating to the dock attendant to proceed with caution.

CONSTRUCTION: The TPR[®] restraint system is a truck positioned restraint system designed to be permanently mounted to the loading dock foundation. Restraint back plate and housing shall be in a zinc finish for all weather protection. Once activated, the TPR seeks the RIG and exerts positive pressure to reduce the possibility of premature trailer separation from the dock. The TPR secures the trailer with over 32,000 lbs. of pull-out force. The motor is IP67 rated, making it submersion proof in up to 1 meter of water for 30 minutes

HOOKING RANGE AND CAPACITY: The TPR[®] restraint system is designed to withstand a pulling force in excess of 32,000 lbs., giving an added margin of safety and protection. Maximum operational range is 4" to 10" horizontally from face of dock bumpers, and 9" to 30" vertically above drive approach.

ELECTRICAL: The TPR[®] vehicle restraint is available as a stand alone unit or combined electronically in a single integrated control panel with your dock leveler selection. Electric motor is 1/10 HP TENV 115v single phase. Interior and exterior 12 volt LED lights are powered by an integral transformer located in the control panel. Electrical control panel is a NEMA 4X enclosure.

Please Note: Unless specifically noted on quotation, all electrical requirements, including mounting of control box, outside lights and signs, are the responsibility of others.

EXTERIOR LIGHTS: Low profile, traffic style, red, and green LED lights are standard for communication to truck driver. A set of caution signs warns truck driver to "Back In or Pull Out On Green Light Only".

INSTALLATION: Requires mounting of locking unit, control panel, exterior lights and signs in strict accordance with McGuire[®] installation instructions. TPR[®] can be welded to an optional new construction embed plate or by installing 15 anchor bolts (included) plus 16" of weld to dock curb steel. Mechanical installation is recommended to be performed only by authorized McGuire Representative.

WARRANTY: All TPR[®] vehicle restraints feature a full one (1) year base warranty on all structural, mechanical and electrical parts, including freight and labor charges in accordance with McGuire's Standard Warranty Policy. McGuire warrants all components to be free of defects in materials and workmanship, under normal use, during the warranty period. This base warranty period begins upon the completion of installation or the sixtieth (60th) day after shipment, whichever is earlier the completion of installation or the sixtieth (60th) day after shipment, whichever is earlier.

AUTOMATIC VEHICLE RESTRAINT

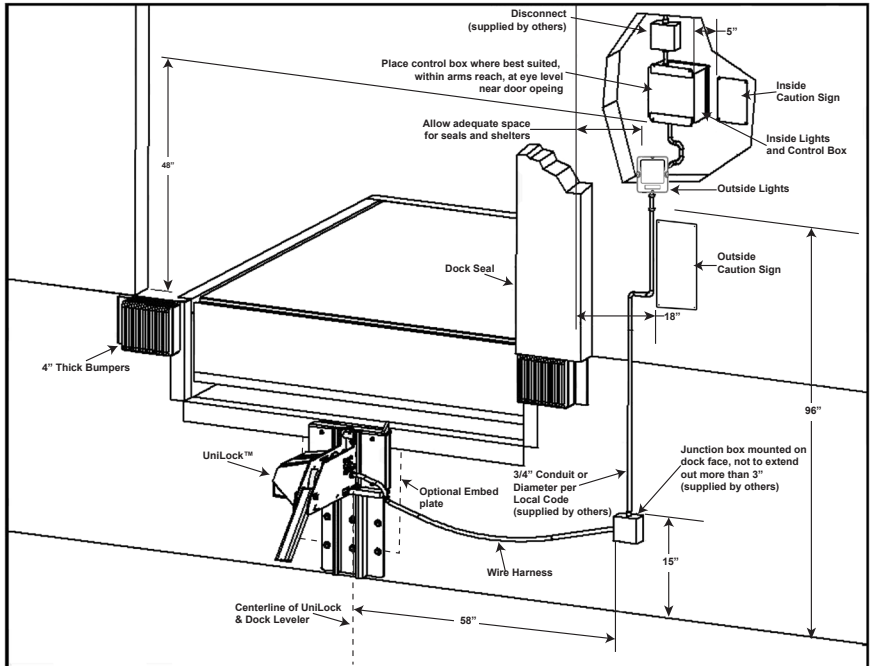
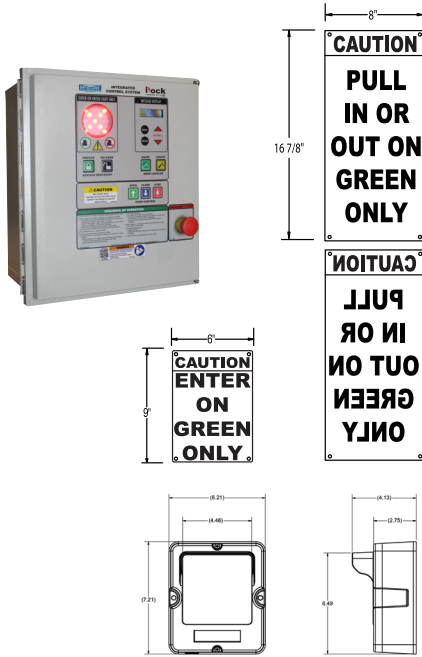

Optional Equipment for TPR® Automatic Vehicle Restraint

Check Options Desired

- | | | |
|--|--|--------------------------------------|
| <input type="checkbox"/> Integrated Control Panel | <input type="checkbox"/> Pit Floor Mounting Plate | <input type="checkbox"/> Other _____ |
| <input type="checkbox"/> Audible Alarm | <input type="checkbox"/> Embed Mounting Plate 20"x20"
(Recommended on New Construction) | <input type="checkbox"/> Other _____ |
| <input type="checkbox"/> Green Light Interlock with Leveler | <input type="checkbox"/> Approach Plate with Bracing
(Brick and Block wall recommended) | <input type="checkbox"/> Other _____ |
| <input type="checkbox"/> Cantilever Bracket _____ Projection | <input type="checkbox"/> Special Nema _____ Enclosure | |
| <input type="checkbox"/> Exterior Strobe Emphasizer | | |

**options must also be selected on the iDock Controls Specification sheet.*

Customer: _____
 Job: _____
 Location: _____
 Number of Units: _____
 Model: _____
 Represented By: _____
 Sales Rep: _____

Certified for Construction:
 By: _____
 Title: _____
 Date: _____
 Company: _____
 City: _____
 State: _____

Consistent with our policy of continuing product improvement, we reserve the right to change product specifications without notice or obligation.

McGuire • Division of Systems, LLC • W194 N11481 McCormick Dr. • P.O. Box 309 • Germantown, WI 53022
 Phone: 800.624.8473 • Fax: 262.255.9399 • www.wbmcguire.com