

McGUIRE

A Division of Systems, LLC

STOP-TITE® SERIES

AUTOMATIC VEHICLE RESTRAINT

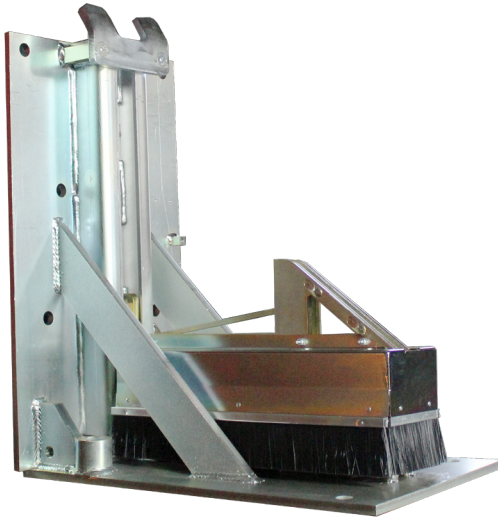

- ▶ Push button activation (single phase operation)
- ▶ iDock® Controls with Interactive Message Display
- ▶ Automatic light sequence
- ▶ RIG sensor bar to notify operator is restraint is not securely engaged to trailer's Rear Impact Guard
- ▶ Low profile, non-impact design (wall or driveway mount)
- ▶ Restraining force in excess of 32,000 lb. average
- ▶ Remote power pack with translucent reservoir
- ▶ Zinc plated finish
- ▶ Interlock terminals
- ▶ Standard 96" hose length for dock face mount
- ▶ Zinc plated finish and protective debris guard
- ▶ Made in the USA

GENERAL DESCRIPTION: All McGuire STOP-TITE® AAL vehicle restraints are designed to secure a cargo trailer's Rear Impact Guard (RIG) to reduce the likelihood of premature trailer separation during the loading process. The exclusive STOP-TITE vehicle restraint features a hydraulic restraint mechanism with power package, inside iDock control panel, exterior communication lights, and instructional signs.

OPERATION: As a trailer backs into position, the exterior light is green and the interior light is red. Once the trailer is positioned against the dock bumpers, the operator presses the "engage" button. The STOP-TITE raises vertically to the RIG and the inside light will display green while the outside light will display red. The dock attendant should visually inspect and confirm that the restraint has engaged the horizontal member of the RIG. After the loading is complete, the operator presses the "release" button. When the trailer is released and the restraint is safely stored the interior light changes to red while the exterior light changes to green.

If the STOP-TITE vehicle restraint is unable to secure the trailer's RIG, an amber caution light as well as a message on the message display will appear. The restraint must be returned to a stored position to turn off the horn. Then "by-pass" must be manually initiated via entering your bypass code and the trailer must be secured by other means before proceeding with the loading/unloading process. The outside red light will continue to blink indicating to the dock attendant that a caution situation is present. Once trailer has left the dock a manual reset of the "by-pass" is accomplished by hitting reset on the controller.

CONSTRUCTION: The STOP-TITE AAL restraint system is designed to be a stationary mount, non-impact device, permanently mounted to loading dock foundation or drive approach. Restraint shall be preserved in a zinc finish for all weather protection. Restraint arm shall be preserved in a highly visible zinc dicromate finish that is highly resistant to corrosion. Once activated, the STOP-TITE AAL extends

upward to the RIG. The uniquely designed restraint arm minimizes "trailer creep", securing the trailer with over 32,000 lb. (average) of pull-out force. The fully automatic STOP-TITE AAL is affordable and easy to install. It is ideal for all manufacturing, warehouse and distribution applications.

HYDRAULICS: The STOP-TITE AAL vehicle restraint is a hydraulically actuated restraint with a Light Communication System. STOP-TITE vehicle restraint raises vertically to find and maintain a hold on the RIG of truck throughout loading and unloading operations. The dual locking restraint arm will minimize "trailer creep". As an optional safety feature, the dock leveler and the vehicle restraint can be interlocked, preventing operation of the dock leveler until the restraint is activated.

HOOKING RANGE AND CAPACITY: The STOP-TITE AAL restraint system is designed to withstand a pulling force in excess of 32,000 lb. (average), giving an added margin of safety and protection. Maximum operational range is 10" horizontally from face of dock bumpers, and 12" minimum to 29.5" maximum vertically. Additional ranges are available for certain applications.

ELECTRICAL: The STOP-TITE AAL vehicle restraint is available as a stand alone unit or integrated with other loading dock equipment through an optional integrated control panel. Hydraulic pump and motor is 1/4 HP requiring 4.6 Amps at 115v single phase. Electrical control panel is NEMA 12 enclosure. All electrical control panel components, connections and wiring are UL listed/ recognized.

Please Note: Unless specifically noted on quotation, all electrical requirements, including mounting of control box, outside lights and signs, are the responsibility of others.

VEHICLE RESTRAINT



A Division of Systems, LLC

STOP-TITE® SERIES

AUTOMATIC VEHICLE RESTRAINT

EXTERIOR LIGHTS: Low profile, traffic style, LED red, and green lights are standard for communication to truck driver. A set of caution signs warns truck driver to "Back In Or Pull Out On Green Light Only".

INSTALLATION: Requires mounting of locking unit, control panel, exterior lights and signs in strict accordance with McGuire installation instructions. Mechanical installation is recommended to be performed only by authorized McGuire representative.

WARRANTY: All STOP-TITE AAL vehicle restraints feature a full one (1) year base warranty on all structural, hydraulic and electrical parts, including freight and labor charges in accordance with McGuire's standard warranty policy. McGuire warrants all components to be free of defects in materials and workmanship, under normal use, during the warranty period. This base warranty period begins upon the completion of installation or the sixtieth (60th) day after shipment, whichever is earlier.

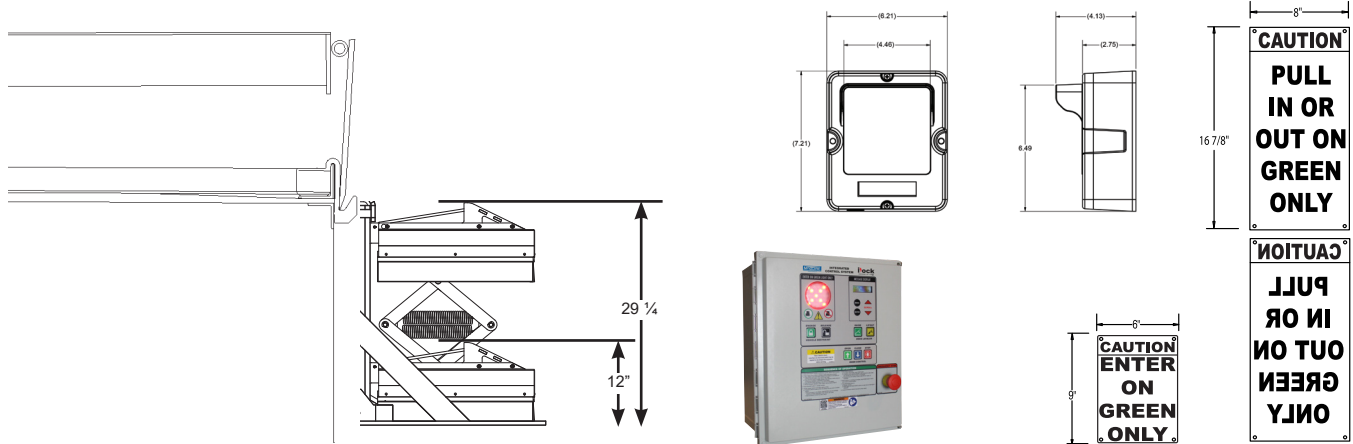

Optional Equipment for STOP-TITE® Automatic Vehicle Restraint

Check Options Desired

- | | | |
|--|--|--|
| <input type="checkbox"/> 126" hose length for leveler pit location (PN 9904-0153) | <input type="checkbox"/> Limit switch for door interlock | <input type="checkbox"/> Key lock override switch |
| <input type="checkbox"/> 180" hose length for remote interior location (PN 9904-019) | <input type="checkbox"/> Integrated control panel (effects panel size) | <input type="checkbox"/> Other _____ |
| <input type="checkbox"/> Other hose length _____ | <input type="checkbox"/> Cantilever bracket _____ projection | <input type="checkbox"/> Other _____ |
| <input type="checkbox"/> Dock leveler interlock | <input type="checkbox"/> Low profile 10" | *options must also be selected on the iDock Controls specification sheet |
| <input type="checkbox"/> Additional interlock terminals | <input type="checkbox"/> Embed plate __ wall __ drive | |
| | <input type="checkbox"/> Anchor pkg. __ wall __ drive | |

Customer: _____
 Job: _____
 Location: _____
 Number of Units: _____
 Model: _____
 Represented By: _____
 Sales Rep: _____

Certified for Construction:
 By: _____
 Title: _____
 Date: _____
 Company: _____
 City: _____
 State: _____

Consistent with our policy of continuing product improvement, we reserve the right to change product specifications without notice or obligation.

McGuire • Division of Systems, LLC • W194 N11481 McCormick Dr. • P.O. Box 309 • Germantown, WI 53022
Phone: 800.624.8473 • Fax: 262.255.9399 • www.wbmcguire.com

VEHICLE RESTRAINT

SS ST-A 9/24